

7

TRAPOFLEX-WORKING PLATFORM "S"

Item No. 743016

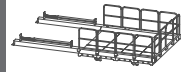

ORIGINAL ASSEMBLY INSTRUCTIONS

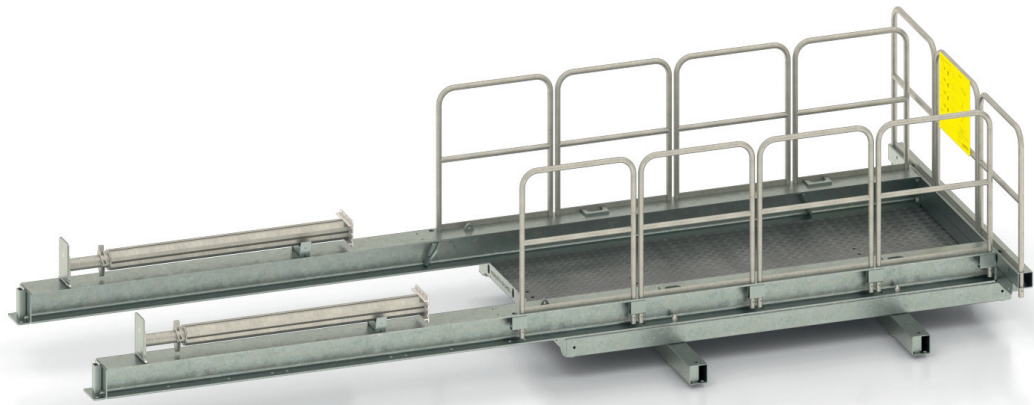

ROBUSTA
GAUKEL



1. General Safety Instructions

1.1. General

- This assembly manual contains information for the correct assembly and proper use of the products described below
- In addition, country-specific rules and regulations must be observed. Furthermore, specific site hazards must be considered during assembly.

In case of uncertainties or questions, please consult ROBUSTA-GAUKEL.

- The depicted assembly states are to be understood as exemplary intermediate states; therefore, they may not always be completely correct from a safety perspective. In general, the regulations of the accident prevention regulations (Health and Safety Executive or equivalent) must always be observed.
- Unauthorized modifications to the components are not permitted. In case of deviations from this manual or any extended use, explicit approval from us is required. In such instances, we kindly request you to consult with the technical department of ROBUSTA-GAUKEL Company.
- ROBUSTA-GAUKEL is responsible for ensuring that a hard copy of this manual is available at the deployment site. The safety of the workforce in specific on-site situations is also the responsibility of ROBUSTA-GAUKEL. In addition to this manual, a general risk assessment has been conducted by ROBUSTA-GAUKEL; however, the on-site team must perform a risk assessment, taking into account the conditions and circumstances at the respective deployment sites. During assembly or installation, adherence to the hierarchy of measures outlined in the Occupational Safety and Health Act is mandatory.

1.2 Copyright

- This documentation is protected by copyright. Any use or modification outside the narrow limits of copyright law is prohibited and constitutes an offense without the consent of ROBUSTA-GAUKEL GMBH & CO.KG..

1.3 Qualified and Authorized Persons

- Individuals who are qualified and authorized, based on their education and training, possess the capability to execute their designated tasks in accordance with technical standards while adhering to safety requirements. The on-site team is responsible for identifying such individuals

1.4 Warranty Claims

- ROBUSTA-GAUKEL assumes no liability for damages:
 - In case of improper use/operation
 - When used in combination with accessories or fastening parts not supplied by ROBUSTA-GAUKEL
 - In case of modifications to components and unauthorized alterations
 - In the event of improper assembly, maintenance, inspection, and upkeep
 - When using parts that are not original components
 - When operated by non-qualified and unauthorized individuals
 - Towards third parties

1.5. Checks

- The functionality of the product must be tested before assembly by a qualified and authorized person.
- All parts must be carefully inspected for damage or any other capacity-reducing impairments and replaced if necessary.
- The components and correct assembly must be regularly checked by a qualified and authorized person, adhering to this manual.
- Non-functional or damaged material must be stored and marked in a way that further use is precluded!
Only original parts from ROBUSTA-GAUKEL are to be used.
- Illegible stickers or nameplates must be replaced!



Important points to be taken care of



Visual inspection



Mounting point for crane hook



2. Intended use

With the TrapoFlex-working platforms a safe stop surface with a surrounding side protection outside of the building can be mounted. So the material for casings and scaffolding as well as component parts for the inside construction can be placed without dangerous diagonal pull by crane. The closed flooring made of corrugated metal sheet is flush with the upper edge of the slab, that means the transportation with lift truck or rollers is possible without any difference of level. The flooring with a complete surrounding setting on edge prevents falling of small parts.

With a few elements the platforms are mountable in different manner. So different standard platform sizes are mountable like an assembly of prefabricated parts. The standard platforms with a width of 2.40 m and 3.00 m are optimized for a transportation by truck.

In general the delivery of this platforms is in a mounted stage. Only the side protection frames have to be mounted on site.

The props for the support are fixed to inclinable base plates.

On request the platforms can be adjusted to special installation situations.

With a few special parts also other platform measurements are possible.

The dimensioning and the proof of the parts are based on DIN EN 12811-1 and -2..

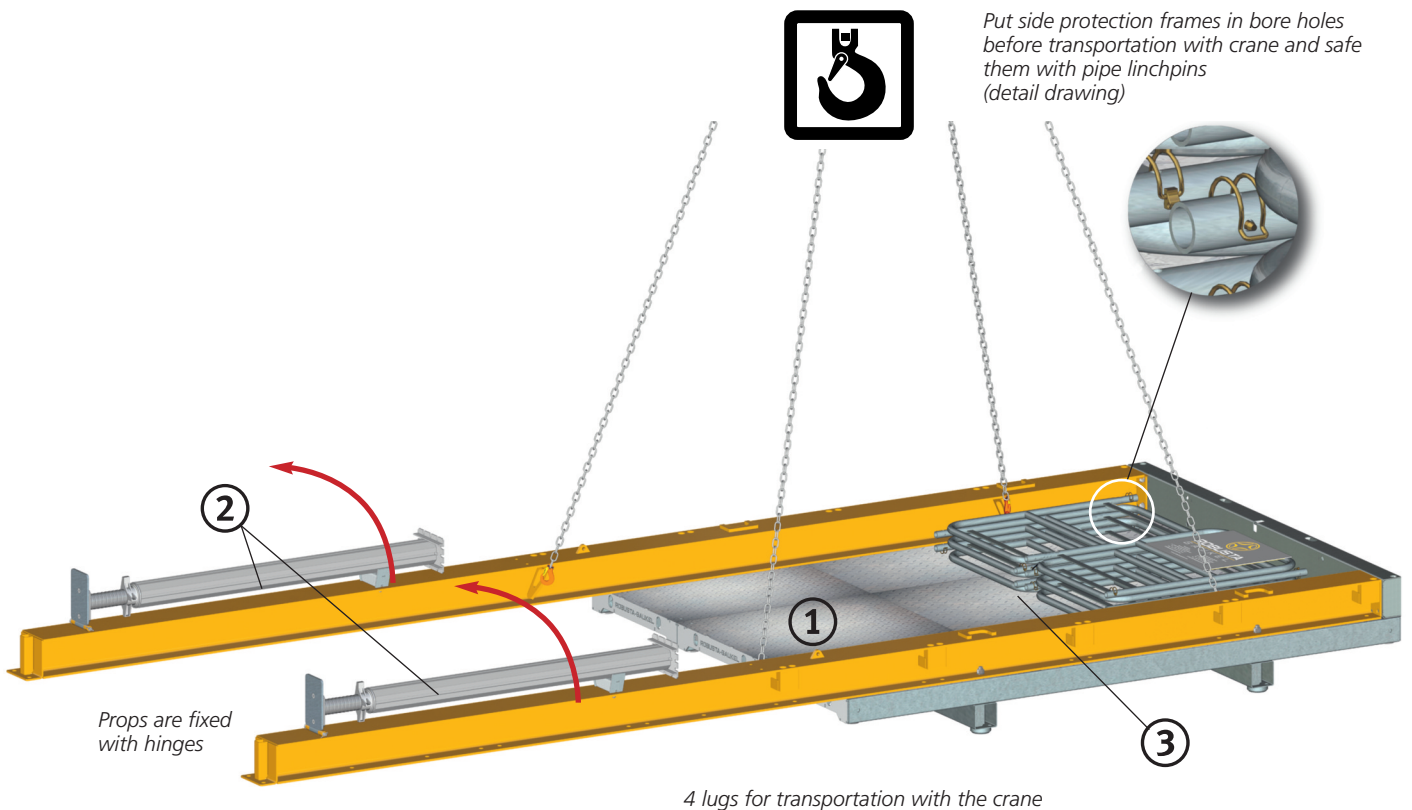

TrapoFlex Type "S", complete

Platform area [m ²]	Permissible area load [kN/m ²]	Permissible point load [kN]	Weight [kg/unit]	Item No.
3.48	6.0	21.0	1170.0	743016

Position	Quantity
① platform consisting of cantilever girders and flooring frames	1
② single props aluminium (L = floor height)	2
③ side protection frames	11



3. Survey of single parts

TrapoFlex Type S

Representation: as-received as pre-installed assemblies

Sizes, weights and suspension points

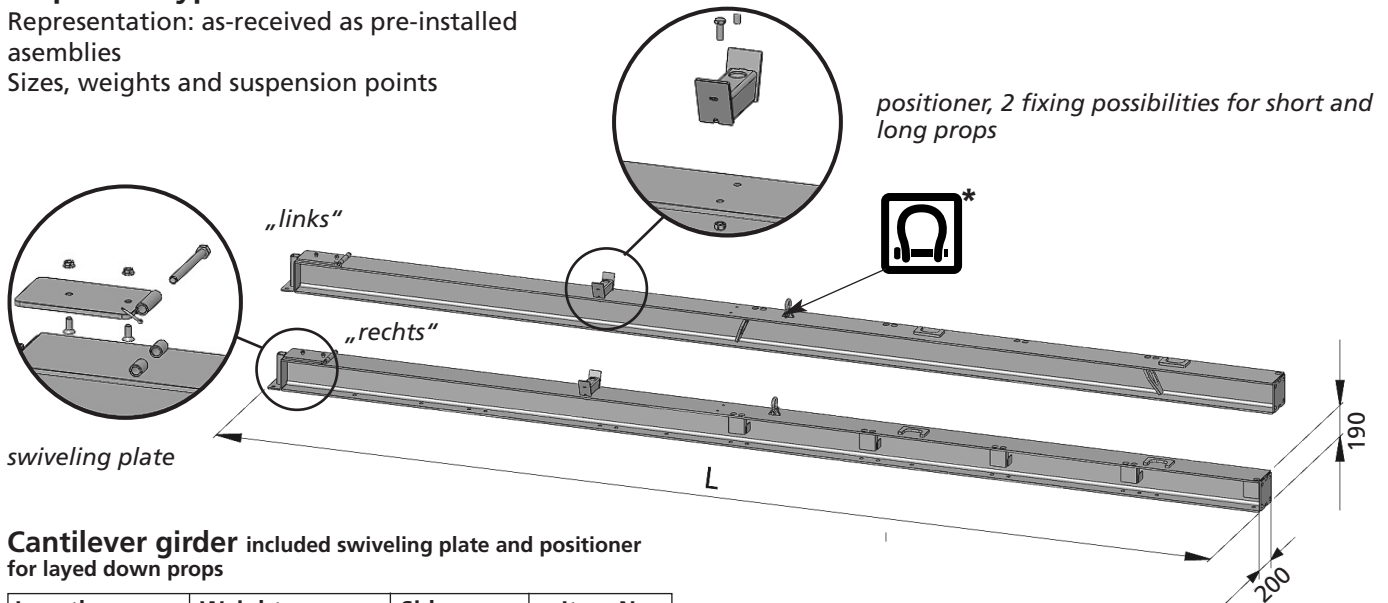

Cantilever girder included swiveling plate and positioner for layed down props

Length [mm]	Weight [kg/unit]	Side	Item No.
6180	275.0	leftside	743073
6180	275.0	rightside	743072

Flooring frame

Sizes L x w x H [mm]	Weight [kg/unit]	Item No.
3000 x 800 x 130	184.0	740008

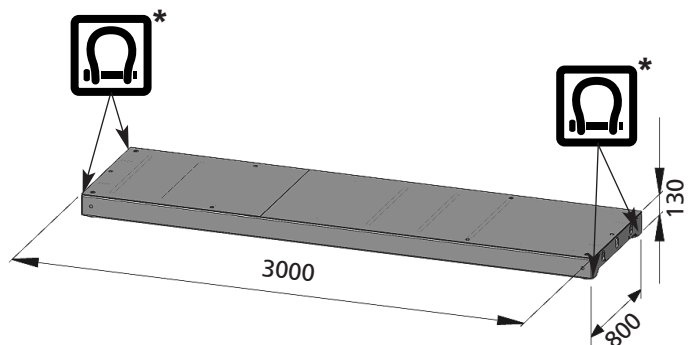

Traverse

Length [mm]	Weight [kg/unit]	Item No.
2400	41.0	740025

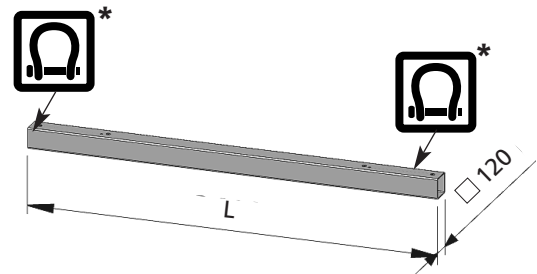

Cantilever for front end

Length [mm]	Weight [kg/unit]	Item No.
2400	36,5	740024

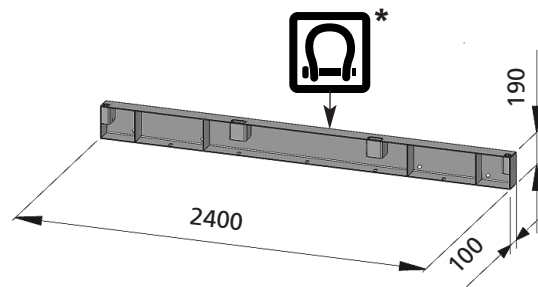

* only for transportation of the single parts near ground!



3. Survey of single parts TrapoFlex Type S

Single props with 1 spindle

Type	Extension length L [m]	Length L 1 [m]	Weight [kg/unit]	Item No.
3-AL	1.70 – 2.90	1.62	17.0	621329
4-AL	2.90 – 4.10	2.82	21.0	621441
5-AL	4.30 – 5.50	4.22	28.0	621555

Additional spindle with protection against unscrewing

Type	Length [m]	Extension length [m]	Weight [kg/unit]	Item No.
lang	1.60	1.20	10.40	621012

Extension elements

Length L [m]	Weight [kg/unit]	Item No.
1,00	5,70	621010

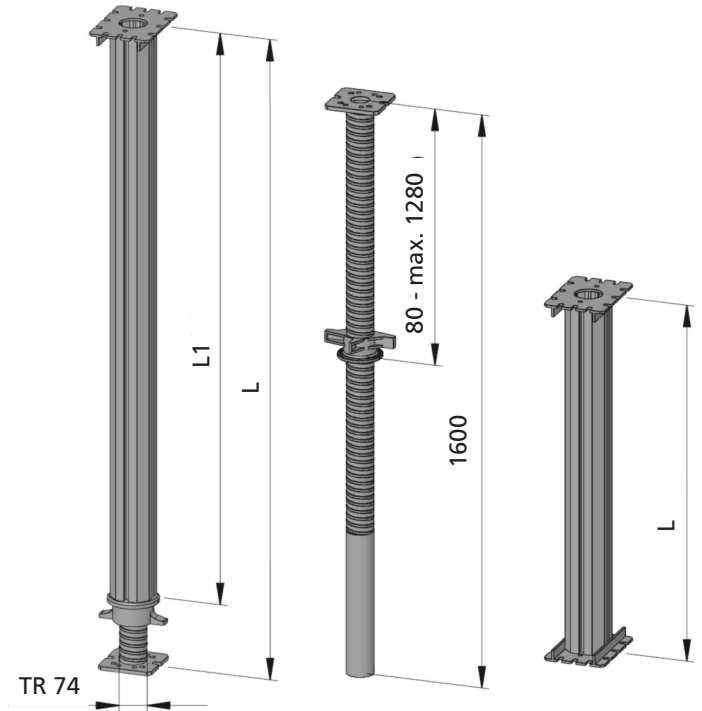

Side protection frame

Weight [kg/unit]	Item No.
9.0	419510

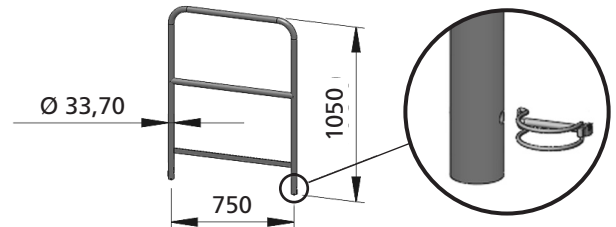

Stacking ring

Weight [kg/unit]	Item No.
1.3	740031

Stacking spacer

Weight [kg/unit]	Item No.
6.0	740034

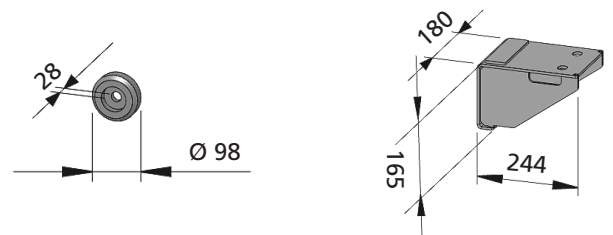

Construction of aluminium

Size of axis W x L [m]	Weight* [kg/unit]	Item No.
1.5 x 2.9	82.0	743110

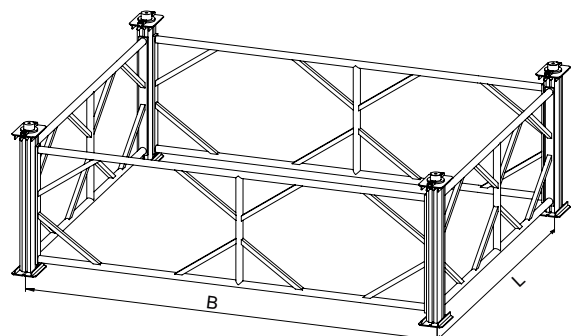

* weight only for tower



4. Stacked TrapoFlex-platform for storing and transportation



Attention: when transporting with fork lift mind the position of the center of gravity!

with stacking ring at the lower side of the traverse

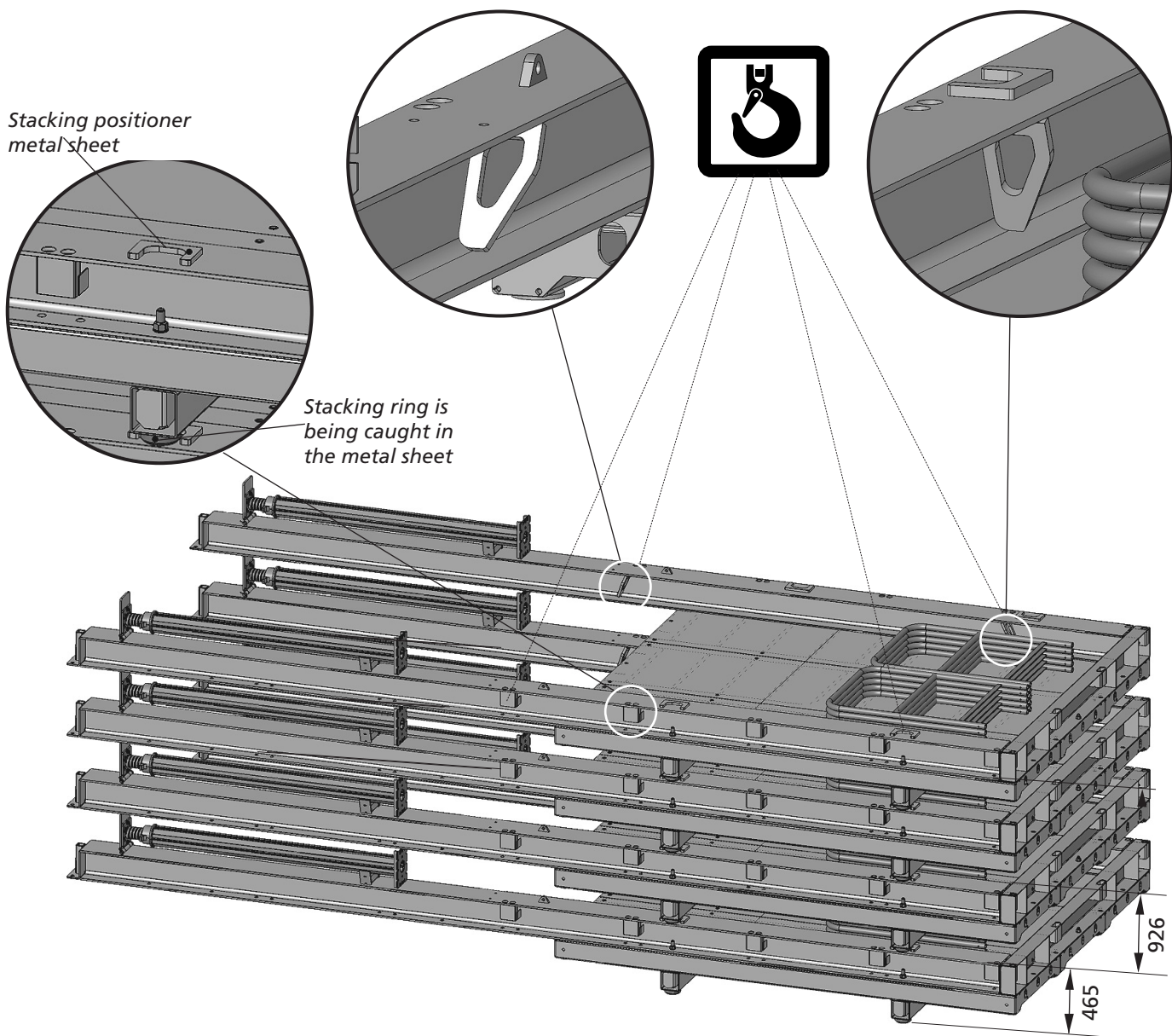



5. Final mounting at the building

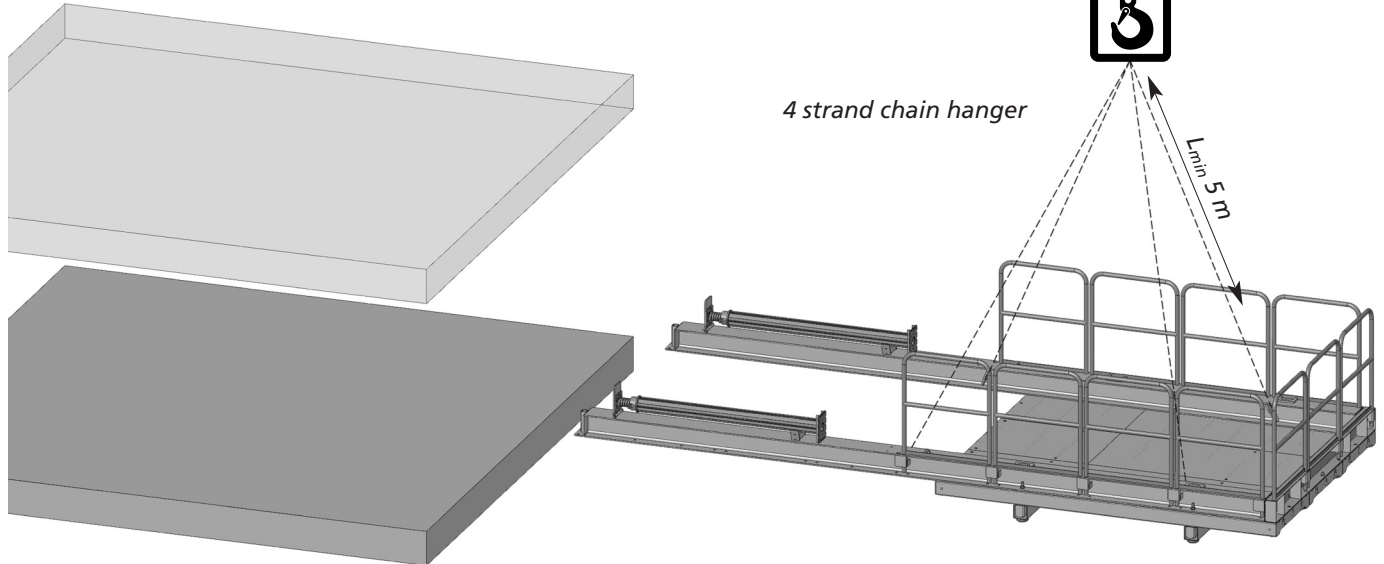

1. Insert side protection railings and secure each with 1 Linch pin
2. Bring in complete mounted platform with crane and place on top of the slab. Platform flooring has to be flush with edge of slab
3. Erect both alu-props and support the platform against the slab above
4. Secure the cantilever girders, which are placed on the slab, with a dowel M12 against shifting. Subsequent secure the two alu-props with a dowel M12 against shifting.

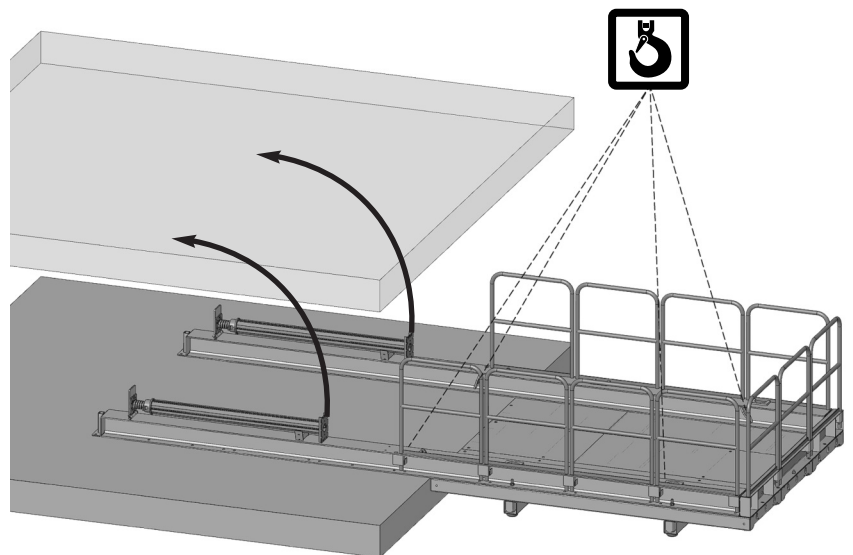

5. Only after that it is allowed to remove platform from the crane!

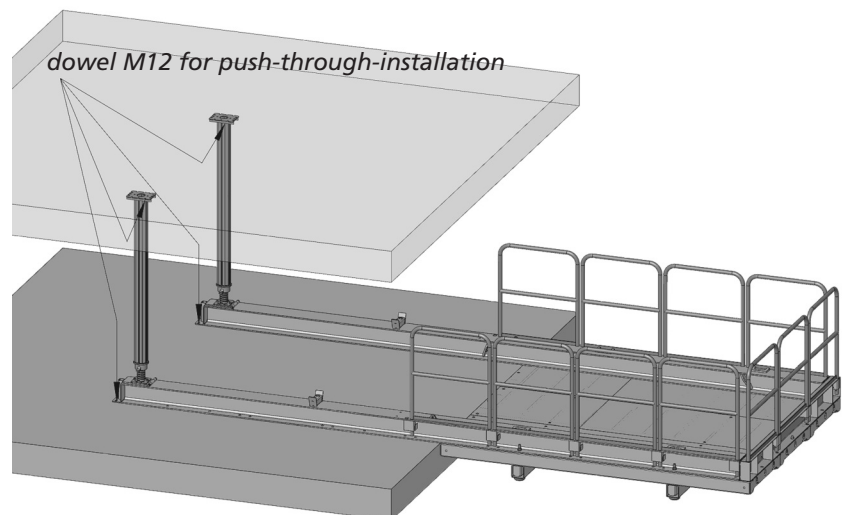



3 A: alternative fixing:

Direct anchoring with tie bars and counter anchoring to the lower slab underneath, if necessary use additional girders for load distribution.

4 A: Remove platform from crane only after that!



After that the platform is ready to use!

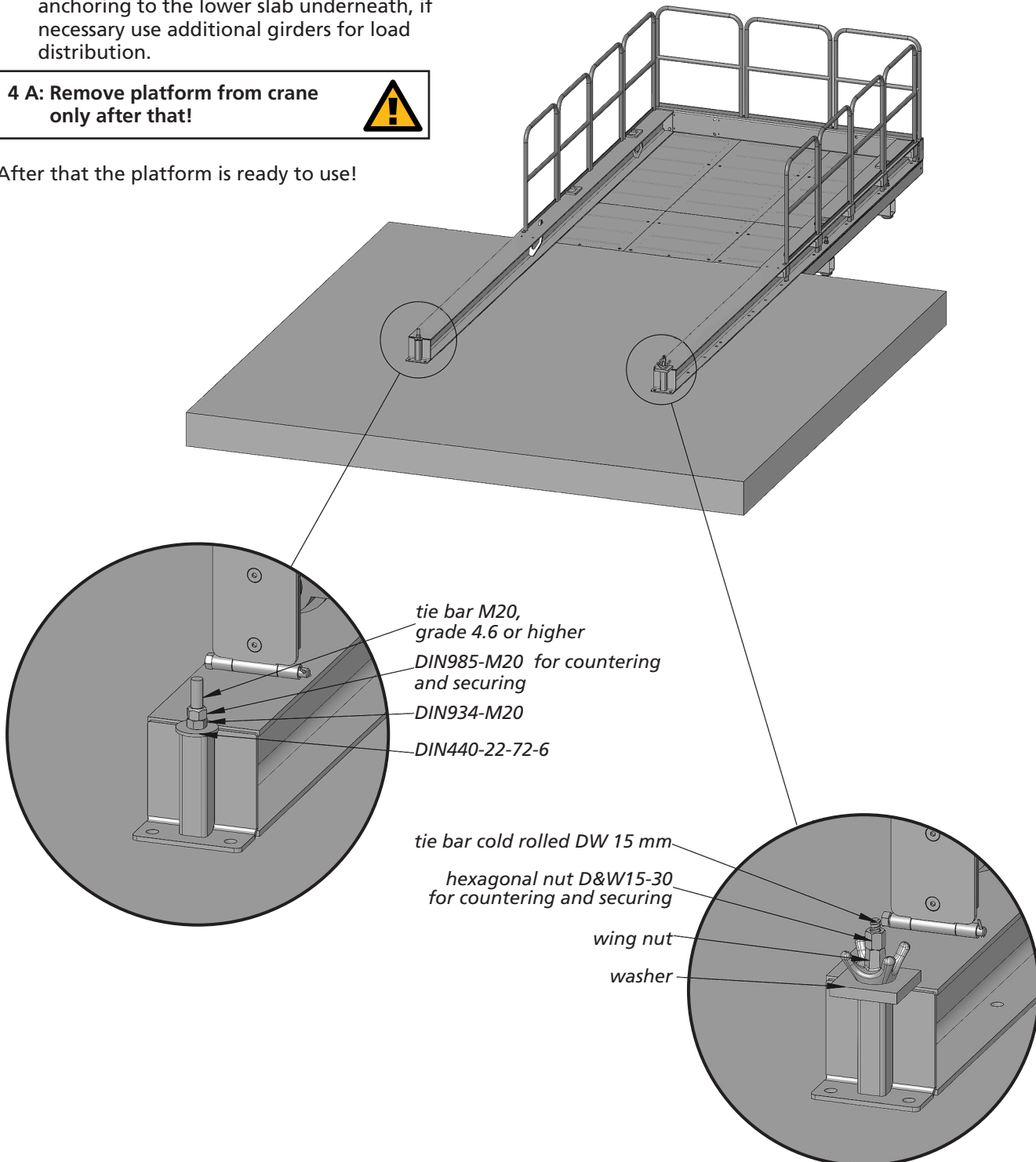

Attention: when dismantling the platform please secure first the platform to the 4 crane hooks with the crane before loosening the supports or anchorings!



6. Components TrapoFlex-working platform Type S

	Part	Item No.	Quantity
	cantilever girder leftside cantilever girder rightside swifeling plate and positioner included	743063 743062	1 x L = 6,00 m 1 x L = 6,00 m
	platform 3000 x 800 mm	74008	2
	traverse girder	740025	2 x L = 2,40 m
	front end girder	740024	L = 2,40 m
	aluminium prop according to room height	3-AL: 621329 4-AL: 621441 5-AL: 621555	2
	guard-rail frame	419510	11
	directions board	740080	1
	stacking-ring	740031	4

Components connection parts for TrapoFlex-working platform Typ S

	Part	Item No.	Quantity
	hexagonal bolt DIN931-M20 x 300 8.8. Zn4	971092	4
	hexagonal bolt DIN931-M16 x 180 8.8. Zn	971078	2
	hexagonal bolt DIN933-M16 x 40 8.8. Zn	971123	6
	counter sunk srew DIN7991-M12 x 30 Zn	971032	4
	hexagonal bolt, self locking, DIN985-M20 8. Zn	973037	4
	hexagonal bolt, self locking, DIN965-M16 8. Zn	973036	8
	hexagonal bolt with flange „Verbus-Ripp“ M12	973004	4
	washer DIN125-21 Zn	974010	4
	washer DIN125-17 Zn	974008	10
	linch pin DIN 94-4 x 40 Zn	972026	2
	dowel M12	149213	4
	linch pin	970029	11
	shackle 1 to. for assembling	119921	4



7. Assembling TrapoFlex-working platform Type S

The TrapoFlex-working platform Type S is delivered already assembled.
For easier mounting we recommend to use square timbers or girders as a helping construction.
Also other supports are recommended such as steel girders or rectangular tubes.

1. Place the traverses on to the square timbers 20 x 10 cm or H20-girders

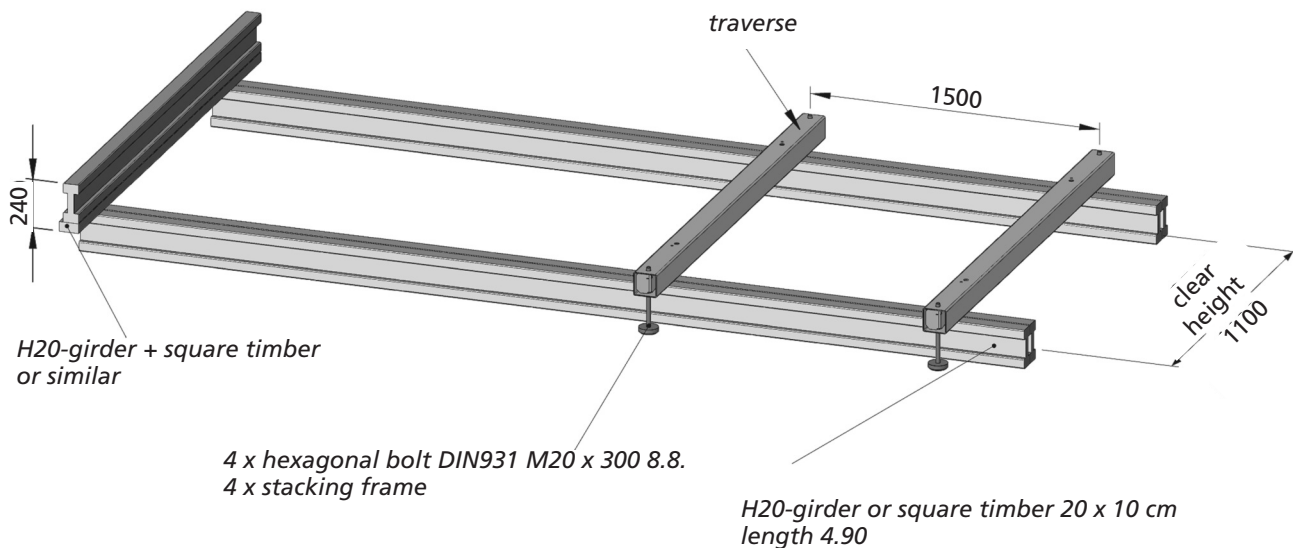

2. Placing the frames on to the traverses

The borings of the frames must be in alignment with the borings of the traverses.

3. Connect the frame in the middle to the two longitudinal profiles of the frames outside with screws. The borings are hidden 60 mm behind the front end plates.

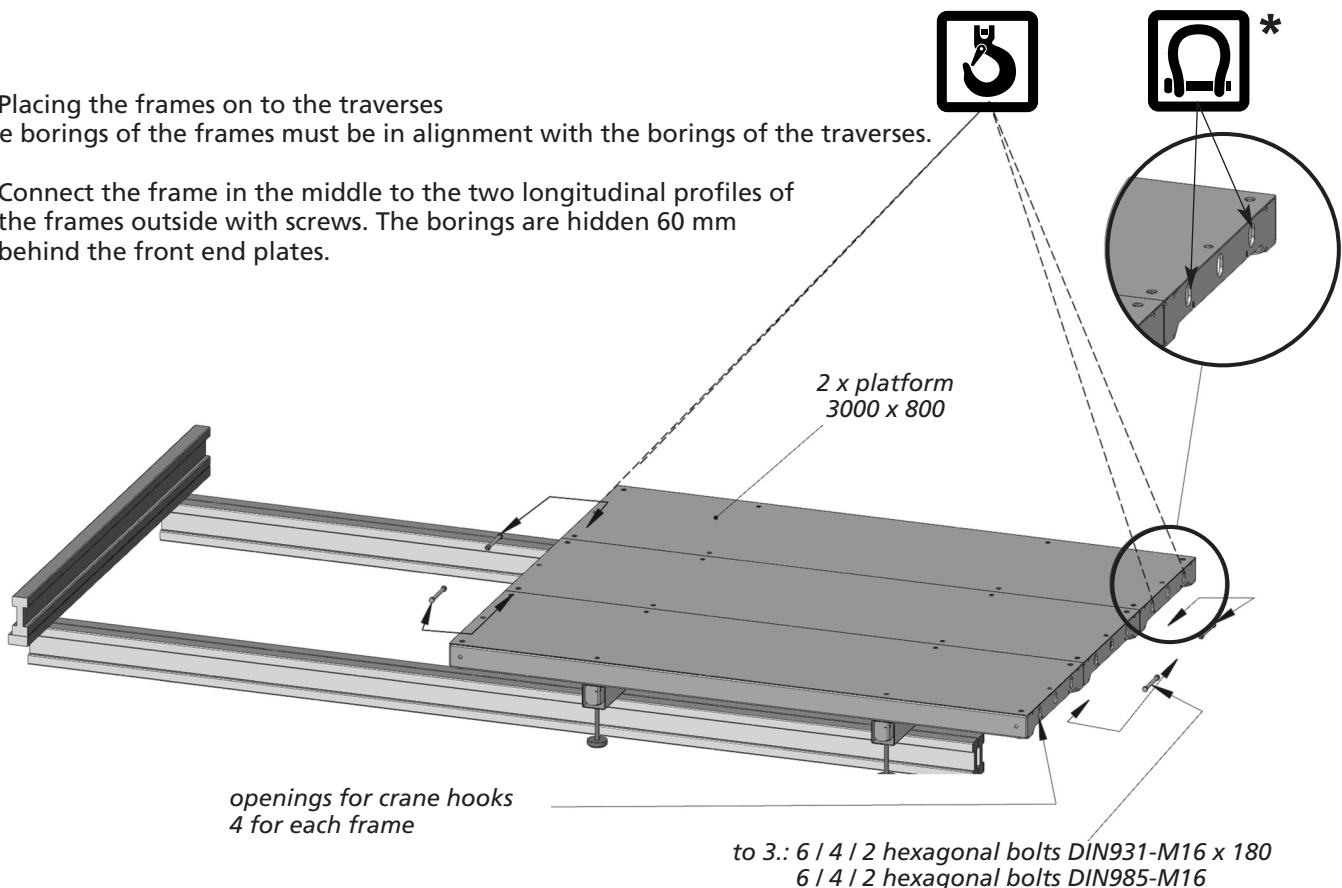

*only for transportation of the single parts near ground!



4. Placing of both cantilever girders "**left-side**" and "**right-side**", borings must be in alignment
5. Screwing of the frames with the traverses and both of the steel beams
6. Placing and screwing of the front end girder
7. Screwing of both of the Alu-props with the cantilever girders



Pick up of shackle in connection with shackle 1 to. Only to be used for mounting of the single beam!

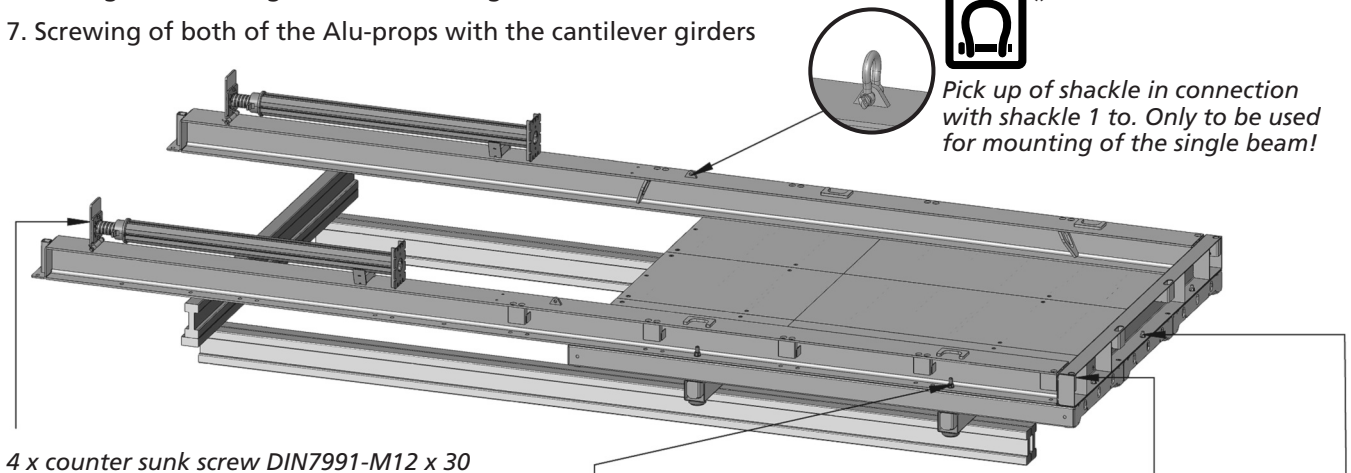

4 x counter sunk screw DIN7991-M12 x 30
4 x hexagonal bolt with flange M12

4 x hexagonal bolt DIN985-M20
4 x washer DIN125-21

4 x hexagonal bolt DIN931-M16 x 40
4 x hexagonal bolt DIN985-M16
8 x washer DIN125-17

2 x hexagonal bolt DIN931-M16 x 40
2 x hexagonal bolt DIN985-M16
2 x washer DIN125-17

***only for transportation of the single parts near ground!**

8. Inserting of the railing frames and securing with linch pin (1 x per frame)

1 frame with directions board necessary!

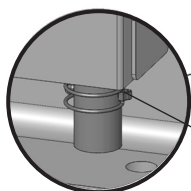
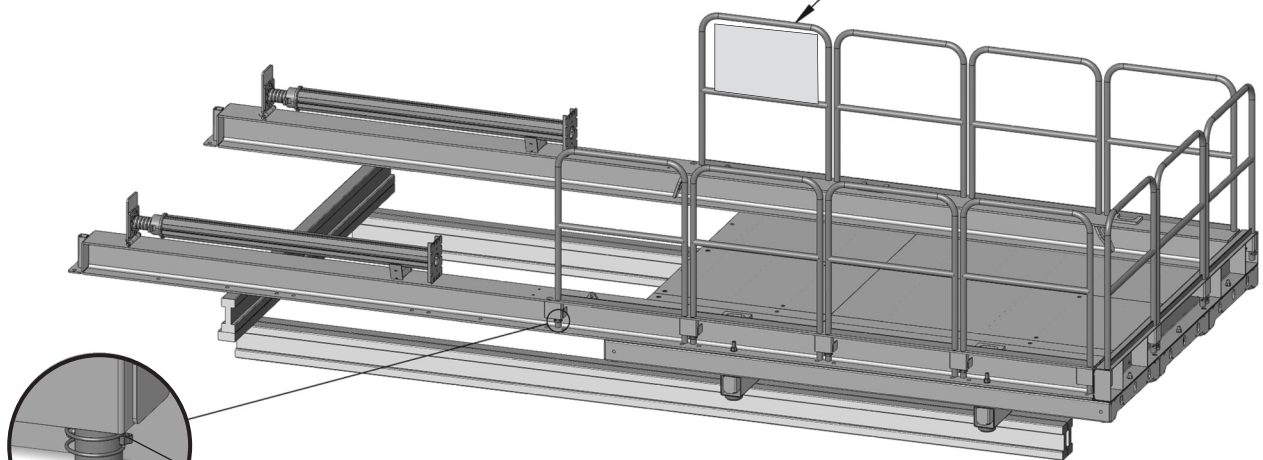

linch pin





8. Disposal

In principle, material that is no longer usable or defective must be disposed properly and professionally in accordance with the applicable legal regulations.

The components are made of galvanized or hot-dip galvanized steel. These can usually be disposed in the steel scrap without further dismantling.



Further information catalogue
7.2. TrapoFlex-working platforms
please scan QR-code



TRAPOFLEX-WORKING PLATFORM "S" – ITEM NO. 743016

7

ORIGINAL ASSEMBLY INSTRUCTIONS

01.08.2022

Page 13 from 14

ROBUSTA-GAUKEL GMBH & CO. KG

Hauptsitz:

Brunnenstraße 36
D-71263 Weil der Stadt-Hausen
Telefon +49 7033 537 10
Telefax +49 7033 5371 31
Internet www.robusta-gaukel.com
E-Mail info@robusta-gaukel.com

Niederlassung Berlin:

Rohdestraße 19
D-12099 Berlin (Tempelhof)
Telefon +49 30 75707000
Telefax +49 30 75707007
Internet www.robusta-gaukel.com
E-Mail nl-berlin@robusta-gaukel.com